

# VFLAH 175



**LONGREACH**  
EQUIPMENT



- Heavy duty model for medium plus hp class tractors
- 3 belt “b” section drive
- Rear door for ease of maintenance and heavy mowing ejection
- Free wheel gearbox to minimize gearbox stresses
- Heavy duty self-centering bearings
- Best quality general-purpose machine
- Hydraulic offset standard
- Rear roller and adjustable skids
- Ideal in narrow vineyard rows
- Manufactured to the highest European standard
- 2 year full factory warranty. Full spare parts availability.

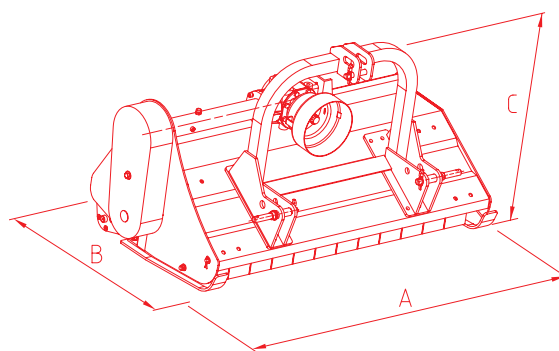

	hp							A	B	C	KG
cm	min	max	cm	n°	n°	n°	rpm	cm	cm	cm	kgs
175	30	70	45 +135 80 + 95	28	56	3	540	187	95	95	350

PRICE