

LONGREACH
EQUIPMENT

IGH180
**OPERATION
AND MAINTENANCE
MANUAL**

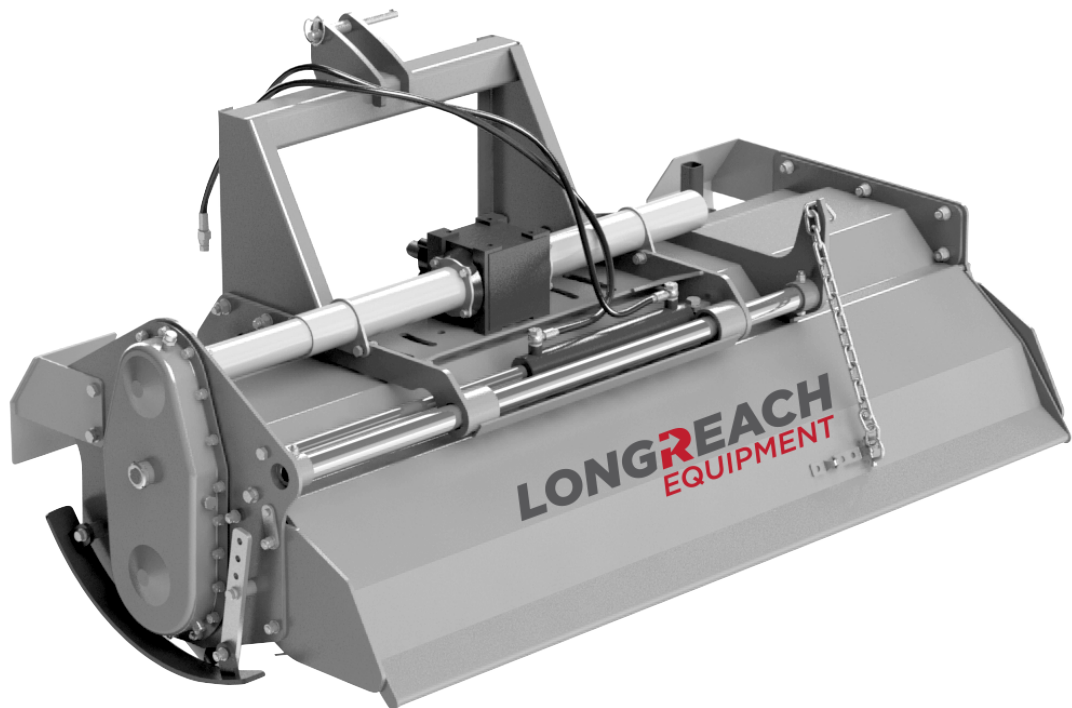

Longreach Equipment wants to thank you for having chosen one of its products.

The technological evolution and the new request of the agricultural world have pushed our firm to a continue improvement, focused on the product, on the quality of the materials and on the quality of work.

The present manual contains the description of the machine and the necessary instructions to correctly use it, along with the instructions for an ordinary and periodic maintenance of the rotary tiller.

Such manual is subdivided in easily recognizable chapters for a practical consultation.

The indications in the present manual are addressed to a professional user, who must have specific knowledge about the driving modalities of the tractor with which the machine is connected. The user has to be authorized, instructed and opportunely trained.

We recommend you to use only original spare parts and accessories.

The use of non-original parts could be dangerous reducing the duration and the performances of the machine as well as the decay of the warranty.

In the case of doubt about the interpretation of the subjects illustrated in this handbook, we suggest you to contact the dealer who will be ready to assist you whenever you need it.

1, GENERAL INFORMATION

1.1 INFORMATION ABOUT THE MANUAL

The using prescriptions shown in this Handbook must be carefully observed to obtain the best performances, to assure the greatest duration of the different parts and to avoid damages to the machine and accidents to the operator.

It is advised the careful reading of the present handbook, to deepen the knowledge of the ROTARY TILLER, before starting to use it.

The present manual is to be considered an integral part of the machine, it must go with the machine in case of resale and till its demolition.

Some illustrations in this manual show particulars or accessories that could be different from those of your machine, some component could have been removed to assure the clearness of the illustrations.

The subjects dealt in this handbook are those expressly requested by the "CE/98/37directive" and by the relatives technical standards.

On the machine are inserted apposite pictogram, which the operator will take care to maintain in perfect visual state and to replace when they are not more readable.

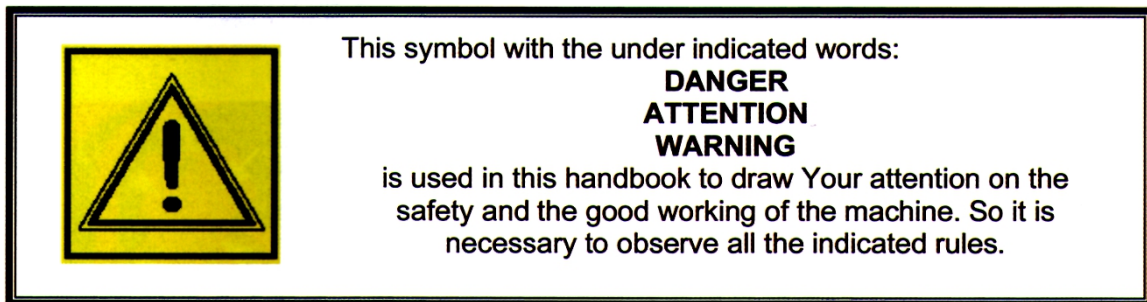

This Handbook has been written following the effective regulations at the moment of its printing. It is an integral part of the machine and must go with the machine with the Declaration of Conformity in case of resale.

1.2 IDENTIFICATION OF THE MACHINE

You will find on frame of each machine: the EC mark and a plate reporting the information about the constructor, the model and the serial number, the year of construction, the weight.



ROTARY TILLER CE	
Type	
Dimensions(LxWxH) (mm)	
Structure weight (kg)	
Serial No	
Date	
CHANGZNOU CLOVERAGRI MACHINERY CO., LTD. 6 JIANYE ROAD, HI-TECH, CHANGZHOU, JIANGSU, P.R. CHINA	

1.3 INFORMATION ABOUT THE MACHINE

Before leaving the production factory this specific model has been subjected to a severe testing to guarantee the greatest reliability.

1.3.1 Foreseen usages

The machines series IGN have been planned and produced exclusively to mill ground.

The machine is not suitable to be used in sectors different from the agricultural one.

WARNING



The rotary tillers with openable hatchback door must be used exclusively with such door (with hydraulic or manual opening) COMPLETELY CLOSED, the use of such door is exclusively of maintenance (we remember that for any intervention on the machine all the instruction in the chapter of this handbook reported must be observed). A use different from the one specified is considered improper.



The machine must be used by one only operator. A use different from the one specified is considered improper.

The machine must be used exclusively by authorized, instructed and opportunely trained people.

This machine is usually used during the day, if exceptionally the night use or in condition of low visibility is requested, the lighting system of the tractor must be used.

Each arbitrary modification made to this machine, releases **Longreach Equipment** from any liability for damages or lesions, serious too, that could occur to the operator, third person or things.

A correct use of the machine, a scrupulous observance of the here listed rules and the strict application of all the precaution to prevent possible dangerous situations, will avoid the danger of injuries or accidents, will let work the machine better and longer and will reduce faults to the minimum.

LONGREACH EQUIPMENT DECLINES ALL RESPONSIBILITIES, OBJECTIVE AND SUBJECTIVE, IF THE RULES REPORTED IN THIS MANUAL ARE NOT OBSERVED

1.3.2 Contraindications

- be sure that on the ground to work there aren't stones or rock of notable dimensions (diameter upper to 10 -15 cm);
- make sure that on the ground to work there aren't tree stumps projecting over about 10cm and of diameter upper to about 10 – 15 cm;
- make sure that on the ground to work there aren't metal elements of every kind, in particular nets, cables, ropes, chains, pipes, and so on;
- observe and apply carefully the instructions of regulation of the height of the machine from the ground, however avoid that in the range of work of the machine till 70 meters other people could stand;
- it is advised never to work "close to the ground" on wet grounds not to compromise the performance and the balancing of the machine, risking to damage the rotor too. In these cases the hoes are too much consumed, notable power is drawn from the engine, there is the risk to HII inside the protective case of the rotor with pressed mud;
- a prolonged work "close to the ground" tends to petrify and to make the ground harder, getting its characteristics worst and compromising the good result of future cultivation.

1.3.3 Noise level

The noise testing have pointed out a Sound Pressure level LAeq equal to 84 dB(A) x 1 dB, measured in open field at a distance of 3 m. from the machine and at 1.6 m. on working land, in continuous maximum allowed working rate conditions.

According to these information it is recommended to wear an individual ear protection.



WARNING

The cleaning, the regular maintenance of the machine and the periodic lubrication contribute to reduce the sound emissions of the machine.

Though there is a connection between the sound emission and the exposure level, this datum can't be used to determine if it is necessary to take some precautions. In fact other factors exist that can affect the sound exposure level, such as for example the characteristics of the working environment and the presence of other noise sources. The information about the noise level emitted by the machine will however help the user or the employer in the writing of the valuation of the dangers and risks.

1.3.4 Storage

If the machine is not used for a long period it is necessary to store it in a sheltered place in order to protect it and to avoid dust accumulation. Before the storage we recommend to clean carefully the whole machine and to oil carefully the mechanic parts to protect them from the rust.

Before storing the machine for a long period, we recommend to operate as follows:

- wash carefully the machine;
- make a general sight checking of the machine to locate possible structural lesions, notice possible deep scoring on the painting, verify that the original safety pictograms are present in their right position, that they are complete and readable;
- grease all the mechanical parts, such as the tightening bolts, the joint shaft to the PTO shaft;
- recover, if possible, the machine in a covered room and lean the machine on wood boards on a flat surface;
- cover the machine with a sheet, binding it opportunely.

The used oil must not be dispersed in the environment, because, according to the effective law regulations, it is classified as special waste, and as such it must be given to the special collect centre. Please apply to the nearest Consortium of used oils.

1.3.5 Scrapping

In case of scrapping the machine should be disposed in appropriate dumps observing the effective legislation.

Before proceeding to the scrapping it is necessary to separate the plastic or rubber parts, the electric and electronic material.

Recover the possible run-down oils and dispose them in the appropriate collection centers. The parts completely made of plastic material, aluminium, steel, can be regenerated if collected in the special centers.

1.4 TECHNICAL DETAILS AND IDENTIFICATION OF THE COMPONENTS

These machines are suitable for low and medium power tractors. They are suitable for forest and gardening. They are composed of a supporting frame in electric-welded steel bringing the joints for the connections to the tractor, power a power transmission system composed of an angular dismissal.

The models of this manual are brought by the tractor through 3 points joint, and act on the ground with their own weight and rotation of the power-taking.

By regulating the height of the lateral slides, it is possible to vary the working height of the machine.

1.4.1 Identification of the components

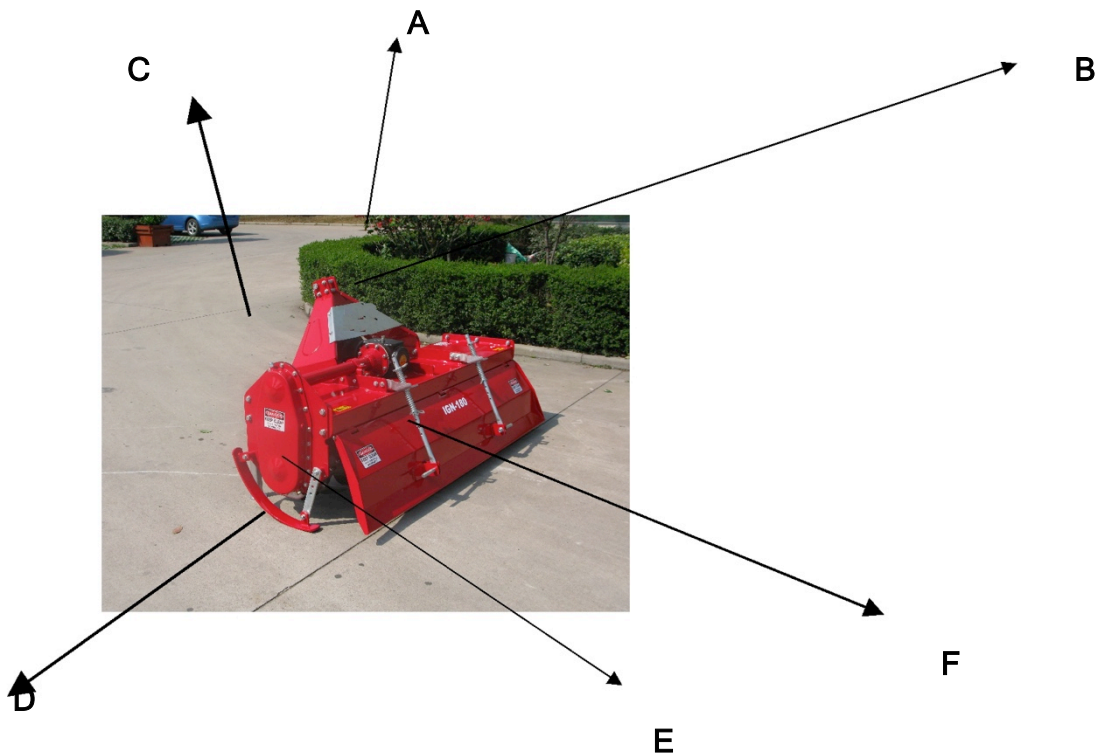

- A. Third point joint
- B. Lateral joints
- C. PTO shift support
- D. Lateral support slides
- E. GEAR drive
- F. Knives-bearing rotor

THE FOLLOWING SAFETY PRESCRIPTIONS AIMS TO PRESERVE YOUR HEALTH: SO IT IS NECESSARY TO READ THEM CAREFULLY, MEMORIZE THEM AND ALWAYS APPLY THEM.

2, SAFETY PRESCRIPTIONS

Use the machine, make the periodic checks and the maintenance intervention in conformity with what is foreseen by the effective safety regulations.

The in observance of the regulations or basis precautions about the safety may cause accidents during the working, the maintenance and the repairing of the machine.

The **Longreach Equipment** ROTARY TILLER has been produced and planed exclusively to cut grass, brushwood, prune remaining and corn trees, every other use modality must be explicitly authorized by the Company on a written document.

Any unauthorized modification on the machine excludes the company's responsibility.

WARNING



Longreach Equipment is not responsible for any possible damage caused by a not foreseen or inadequate use of the machine.

The machine must be used only by authorized, trained people, who know its potential dangers. If you have any doubt, do not hesitate to contact one of our technicians. The instructions written in this manual must be observed carefully.

2.1 SAFETY AND ACCIDENT- PREVENTION RULES



Verify carefully the machine before to turn it on

Longreach Equipment can't foresee all the possible circumstances which might create a potential danger. The warnings presented in this document are therefore not exhaustive

-Observe, besides the warnings in this manual container, all the general safety and accident-prevention regulations. Do not let the machine work or make the maintenance till the instructions have not been read and understood.

-The signals applied on the machine give a series of important indications: their observance is useful to your safety.

- Make sure that all the safety pictograms are readable. Clean them and eventually replace them with new labels.



WARNING

Before to begin to use the machine You need to know every devices, controls and functions, carefully read the present handbook.

- Before using the machine make sure that all the safety devices are correctly placed and in a good state; in case of breakdowns or damages to the protections replace them immediately. In particular check that the front panels are present and complete, free to swing around the bolt on which they are hinged.

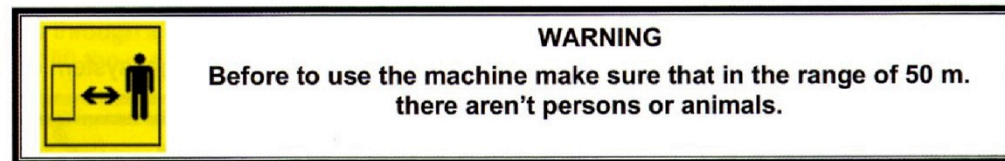
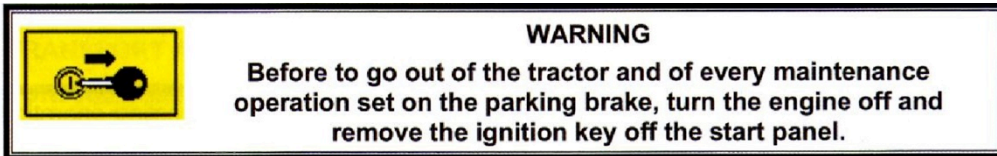

- The handbook must always be in an handing distance, allowing you to verify the operative cycle. If the book is lost or damaged you can ask to **Longreach Equipment** for a substitutive copy - The machine must be used exclusively by authorized, instructed and trained people.
- The machine is planed to be used by only one operator.
- Do never work with this machine if you are tired, ill or under the influence of alcohol, drugs or medicines.
- It is recommended to the operator not to wear articles of clothing that could cause catching (sleeves without closed cuffs, belts, necklaces, bracelets, rings).



- During the use the rotary tiller can give place to dust-emissions, in case of work with wet ground. It is advised to use tractors equipped with cabin with filters on the fan system or to use suitable protection systems of the respiratory tract such as anti-dust masks or masks with filter.
- Do not move the machine when the shredder is working.
- The machine must not be let unguarded when started.
- Check that the machine hasn't been damaged during the transport and in this case warn **Longreach Equipment** immediately.
- Keep the machine clean from foreign materials (rubbles, tools, various objects) that could damage the working or the operator.

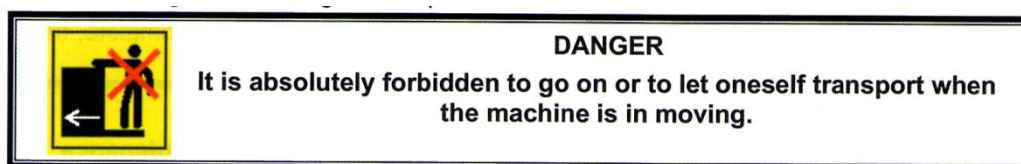

It is absolutely forbidden to go on or to let oneself transport when the machine is in motion.

- Make sure that the PTO shaft is correctly engaged after each connecting operation of the machine.
- Disconnect the machine from the tractor only on a compact and flat round, verifying that it is still and stable.
- Use the machine with enough natural light or, in alternative, use the light system of the tractor.

	<p style="text-align: center;">WARNING</p> <p style="text-align: center;">Verify that the protections of the PTO shaft are complete and in good state.</p>
--	---

- In case of breaking or deterioration of the protections of the PTO shaft, take care of their immediate replacement.
- Verify the wear state of the hydraulic pipes. In case of deterioration take care of their replacement. In any case replace the hydraulic pipes every 5 years.

	<p style="text-align: center;">WARNING</p> <p style="text-align: center;">Do not interpose oneself, for any reason, between the tractor and the rotary tiller with the engine of and the power taking connected.</p>
--	---

	<p style="text-align: center;">WARNING</p> <p style="text-align: center;">Make sure that the rotary tiller is completely still before to approach to the machine.</p> <p>The prolonged use of the rotary tiller can cause the heating of the gearbox, of the transmission protection carter and of the elements of the hydraulic circuit. DO NOT touch these elements during and immediately after the use to avoid burns.</p>	
--	--	--

- Any changes on the machine may cause some problems. In this case the user will be the only responsible for possible accidents.

	DANGER Do not tamper, remove or make inefficient the protections and the safety devices applied to the machine for the safety of the operator and of others. The user can make exclusively the maintenance operations in this handbook described.
---	--

Use exclusively original spare parts of Longreach Equipment.

Longreach Equipment considers itself released from each possible responsibility in the case of:

- Improper use of the rotary tiller by not trained people;
- Serious lack in the foreseen maintenance;
- Not authorized changes or interventions;
- Use of not original spare parts;
- Total or partial inobservance of the instructions;
- Inobservance of the common safety standards in the working range;
- Outstanding events

WARNING

 **BE SURE** that the safety pictogram are readable. Clean them using a cloth, with water and soap. Replaced the damaged labels placing them in the correct position as it is described in the images below.

2.2 SAFETY SIGNALS

2.2.1 Location of the pictogram on the machine

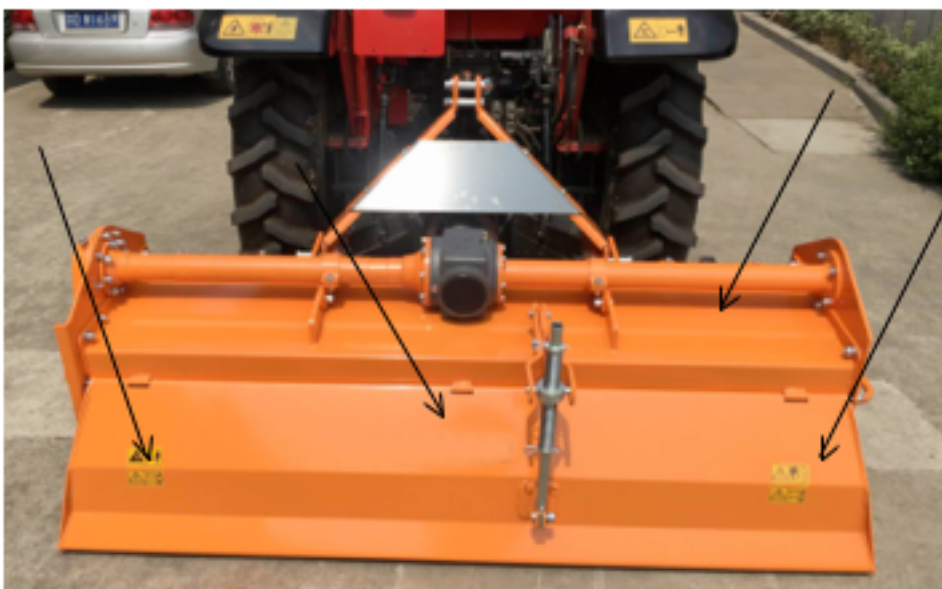

2.2.2 DESCRIPTION OF THE PICTOGRAMMS



1. **WARNING** The operations of regulation and maintenance must be carried out after having read the use and maintenance handbook, with the machine still and the disengaged ignition key



2. **WARNING – DANGER** of fluids under pressure. Read the handbook before to intervene and in case of injury address to a doctor.



3. **WARNING** Make sure of the rotation direction and of the number of revolutions (540 rev./min.) of the power taking of the tractor before to insert the PTO shaft.



4. **WARNING – DANGER** Make sure that the rotary tiller is completely still before to approach to it.



5. **WARNING – DANGER** of shearing of the feet. Keep the distance.



6. **WARNING** Possible throw of material and/or objects, *do not stand, get through or approach to the machine.*

Keep a minimum safety distance of 70 m from the machine



7. **WARNING** It is forbidden to go on the machine when it is in movement.



8. **WARNING** Danger of catching and dragging. Do not approach the hands to the transmission shaft in motion.



9. **WARNING** Do not stand between the tractor and the machine.



10. **DANGER** of crash for the legs. Keep the proper distance.



11. **DANGER** of squashing / shearing of the hands.



12. **WARNING** Hot surface. Keep the proper distance



13. **WARNING** Do not remove or open the protection carters till the transmission are completely still



14. **WARNING DANGER** of squashing. Do not stand in the move and side shifting zone of the machine.



15. **WARNING:** for the lifting, hook the machine exclusively in the indicated points.



16. Use the requested Individual Protection Devices.



17. Greasing points (see par. 6.4)

3, TRANSPORT AND INSTALLATION

3.1 UNPACKAGING AND POSITIONING

Take the maximum care to the safety during the loading and unloading operations, that shall be performed by qualified personnel (slingers, truck operators, and so on).
For the transport the machine must be positioned on pallets, fixed with suitable belts, and moved through a loader with a fit lifting ability.
Do not lift the machine with belts.



For the lifting of the machine use safety hooks or cables of suitable ability to insert in the preset eyebolts for the lifting indicated by the pictograms applied on the machine.

3.2 CHECK OF THE CAPABILITY AND OF THE STABILITY OF THE TRACTOR

Verify the lifting capability and the stability of the tractor through the following formula and if necessary apply frontally the ballasts.

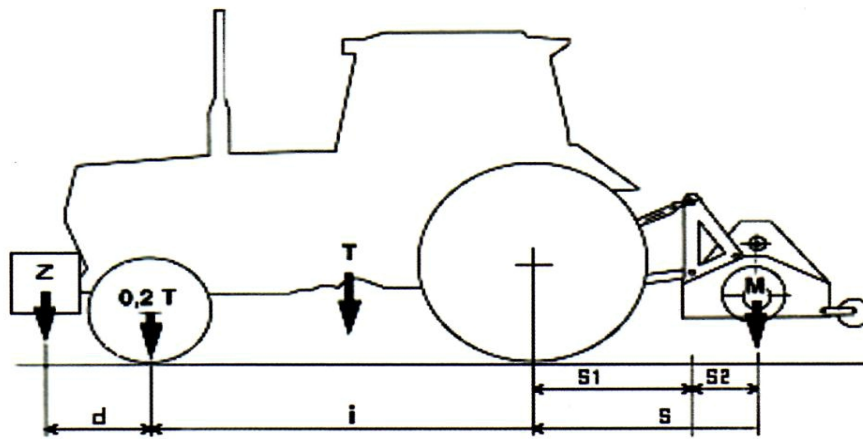

$$M \times s \leq 0,2 T \times i + Z (d + i)$$

$$M < 0,3 T$$

i	=	axle base wheels tractor
d	=	distance of the front axle from the ballasts
S	=	overhang of the rear axle of the operator machine S = S1 + S2
S1	=	distance of the tractor front axle to the end lifting arms
S2	=	distance of the shredder barycentre to the centre holes lifting pins
T	=	mass of the tractor + 75 kg (operator)
Z	=	Mass of the ballasts
M	=	mass of the whole loaded machine



DANGER!

It is obligatory to verify the lifting ability and the stability of the tractor to avoid its turnover and/or loss of adhesion of the steering wheels.

4,CONNECTION TO THE TRACTOR

The behaviour on the road, the steer and brake capacity are influenced by the used tools. The front axle of the tractor is lightened in relationship to the weight attached at the moment of the coupling to the lifting arm: the loading of the front axle must be at least 20% of the weight of the empty tractor.

Before the connection of the machine to the 3 points joint, position the safety device of the tractor to make impossible the unwanted and/or casual lifting and lowering.

The 3 points joint of the tractor and of the machine must coincide or be adapted.

In the rods zone of the rear lifting arms of the tractor there is the danger of injury owing to squashing and cutting points.

Do not use the outside control for the lifting of the machine.

In the transport position block the side halt of the rods and the control level of the lifting.

4.1 CONNECTIONS



4.1.1 Assembly of the rotary tiller and regulations

The machine is equipped with bolts for the 3 points joint of the tractor.

For the connection of the structure of the machine to the tractor operate as follows:

- Approach the tractor to let the lifter bars coincide with the 3 points joint and connect them through the bolts on issue.

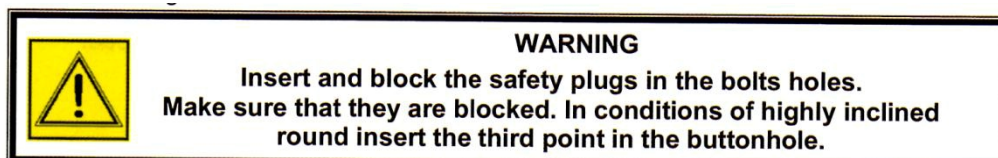

-Connect the third point to the upper joint and regulate it to position the machine in a parallel way to the ground. Verify that the knives or the hammers of the rotor shaft, when the machine is to the round, don't touch the round during the rotation. In the versions equipped with slides verify that these lean on the round along its whole surface.

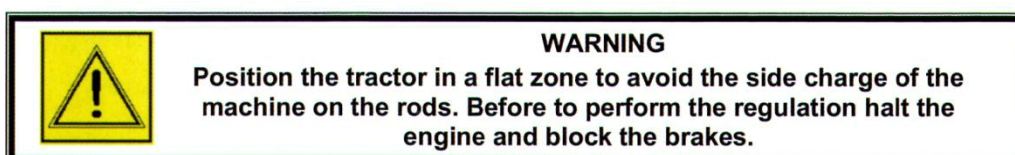

4.1.2 Connection to the PTO shaft

After having executed these operations you can connect the transmission PTO shaft of the power taking to the grooved shaft of the gearbox of the machine (covered by a protection counterguard) and then to the power taking of the tractor:

- clean and grease the power taking;
- grease, if necessary, the PTO shaft following the indications given by the producer of the PTO shaft (see Use and Maintenance Handbook of the PTO shaft):
- clutch the PTO shaft observing the mounting sense prescribed by the producer and indicated on the outside covering of the protection.
- Hitch the anti-rotation chain.
- Make sure that the anti-withdraw safety block (push button) is correctly inserted and blocked in its own housing.

	<p style="text-align: center;">WARNING</p> <p>Verify that the speed regulation of the power taking of the tractor is on a value of 540 rev/min. The PTO shaft must be always connected at last to the power taking of the tractor and disengaged at first at the end of the working.</p>
---	---

When disengaged, the PTO shaft, must be connected to the apposite support.
For a correct and sure working of the machine use exclusively PTO shaft with EC mark.
The length of the PTO shaft must be suitable to the kind of tractor that is used.

Longreach Equipment is not responsible for any damages caused by a non correct use of the cardan transmission

4.1 .3 Hydraulic connections for lateral shifting

Switch the engine off (if on), set the handbrake on and remove the ignition key off the start panel

Verify that there isn't pressure in the hydraulic system of the tractor.

Connect the hydraulic pipes with rapid clutch to the tractor after having checked that all the joints are clean and in very good preservation state.

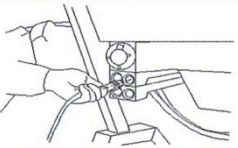
	<p>Make sure that the hydraulic pipes are connected in correct way respecting the colour recognition code and remembering that their inversion causes opposite movements to the ordered.</p>
---	--

Give pressure to the hydraulic system, verify that there aren't drippings and that the connection is correct.

As the milling operations are finished, the hydraulic pipes released from the tractor must be fixed in the apposite supports for this purpose foreseen.

Before connecting, turn the hydraulic pipes off, stop the engine of the tractor and set on in both senses the control levels to let the oil flow from the system.

5 , USE OF THE MACHINE

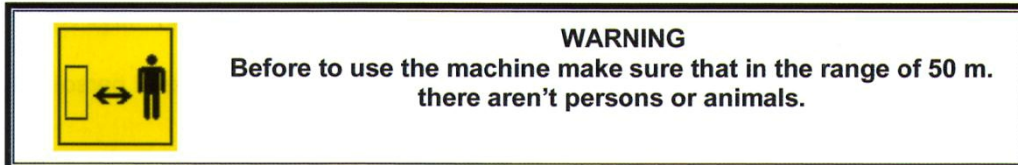

Before starting to work you need to regulate the machine to obtain a good working trim (see "Assembly and regulation", par. 4.1.1).

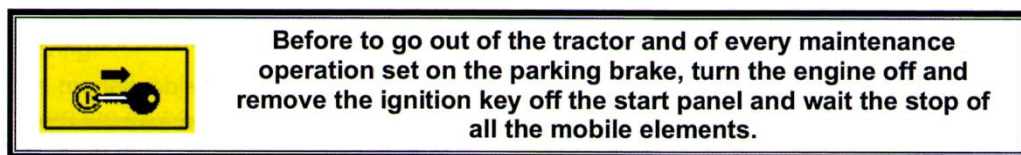

During the work do not take curves with the machine to the ground, nor work in reverse. Always lift the rotary tiller for the direction changes and the curves, inserting first the power taking.

During the use the rotary tiller can give place to dusts emissions, in that case you are working with a dry ground. We recommend to use tractors equipped with cabin with filters on the fan system or, to use suitable system for the protection of the respiratory tract such as anti-dust masks or masks with filter.

It is very important to remember that the road holding, steering and braking capacity may be even notably influenced by the presence of a towed or mounted implement .

Always take care of the centrifugal force exercised by the furthered position of the center of gravity, when turning corners with the implement mounted.

Periodically check that all nuts and bolts are fully tightened .Re-tighten them if necessary.

USE INSTRUCTIONS:

MACHINES SUPPLIED PARTLY BROKEN -DOWN:

When large volumes are involved, machines can be supplied with parts detached or removed (but always in the same packing units).

Normally the 3-point frame is shipped separate and will later be fixed to the machine at the customer's premises.

BEFORE USE:

Before starting the machine , check that:

- The machine is perfectly in order, that the lubricants are at the correct levels and that all parts subject to wear and deterioration are fully efficient.
- Check the rotary tiller, is correctly positioned for obtain the right working depth

The accident prevention guards are delivered dismantled for shipping volume needs. Before commission the rotary tiller, check to be certain than all accident prevent guards are in place and correctly installed.

- The protection unit, consisting of the coupling that as a clamp for the pipes locked by the bracket and by the screws, is fixed to the square front pipe by the U-bolts and should be positioned as far outwards as possible ,one on the right and the other on the left.
- The shaped protections should be fixed laterally with screws to both the sides.
- Strictly comply with the following instructions to achieve the best performances.

WARNING

- **None of the following servicing ,adjustment and preparation operations must be carried out unless the pto is disengaged, the machine is on the ground ,the tractor engine is off and the tractor itself is safely at a braked.**

HITCHING TO THE TRACTOR

- The rotary tiller is coupled to the tractor with the cultivator the ground.
- The ground area should be flat.
- All the rotary tiller can be attached to any tractor with a class 1 or 2 universal 3 -point hitch.

DANGER

- **Application of any implement to a tractor is a very dangerous operation and must only be carried out with the utmost care in compliance with the instructions.**
- The correct tractor/steerage hoe position is established by setting the implement at such a distance from the tractor that the universal coupling remains 5-10 cm from its maximum closing position. Now proceed in the following way:
 - 1 - Near the lift bars, setting them in the most suitable plates. Insert the pin into the relative hole and lock in place with the snap-in split pins.
 - 2 - Lock the lift links using the relative chains and couplings parallel to the tractor . This operation must be carried out to prevent the machine from moving in a horizontal direction.
 - 3 - Engage the cardan shaft and check that it is perfectly locked on the PTO. Check that the guard free to turn and fix it with the relative latch. Re move the cardan shaft support and re-position it by fixing it on the relative hook.
 - 4 - Connect the upper third-point and correctly regulate by means of the adjuster,checking that the upper surface of the steerage hoe is parallel to the ground. This is very important since it achieves parallelism between the axis of the steerage hoe and of the tractor pto.
- When the implement operates in these conditions ,there will be less stress on the pto itself while the cardan shaft and implement will be less subject to wear.

CARDAN SHAFT:

- When the cardan shaft is fully extended, the two tubes must overlap by at least 15 cm.
- When fully inserted, the minimum play must be 4 cm.
- In the implement is used in another tractor, always check the before and that the guards completely cover the rotating parts of the cardan shaft.

Adjusting the cardan shaft with clutch

The cardan shaft can be equipped with safety clutch to protect the transmission components of the machine from stress and/or excessive overloads. The tilt of the cardan shaft must not exceed 10 degrees.

The clutch is already pre-adjusted for average stress. If it slips too easily (and overheats), it will be necessary to evenly tighten all nuts that retain the springs.

The clutch disks must be changed if the clutch still slips after all the nuts have been tightened.

If the clutch does not slip,

evenly unscrew all the spring fixing nuts.

Unscrew one turn at a time and check the clutch after having worked about 300 meters.

If the supplied cardan shaft has a bolt locked hub, check that these bolts are fully tightened.

Repeat the operation if necessary, remembering to unscrew one turn at a time.

If the clutch maintains a temperature of about 40-50 degrees during work, this means that it has been correctly regulated.

Never fully torque the nuts since this would void the function of the springs and, subsequently, of the clutch, thus damaging the transmission components.

This inspection must be performed at the beginning of each new working season.

SHAFT WITH SAFETY LIMITER

The limiter, inserted in the cardan joint, is equipped with a safety bolt that is set for an average force.

Whenever unduly resistant obstacles cause the bolt to shear, it must be replaced by a new bolt, of the same size and material.

If the bolt, inserted in hole shears repeatedly, then we recommend inserting it in the hole

Never allow the steering hoe to operate out of the soil.

During work, avoid turning corners while the implement is soil working.

Never work in reverse. Always raise the implement in order to reverse or change direction.

During transport, or whenever the implement must be raised, it is advisable to adjust the lift unit of the tractor so that the implement itself is not raised more than about 35 cm from the ground.

CHAIN STRETCHER

A special mechanical chain stretcher regulates the tension of the drive chain. If there is too much play, then you must loosen lock nut and tighten screw as much as necessary. Then retighten lock nut which locks the adjustment screw in place.

HOE BLADES

The hoe blades with which the steerage hoe is equipped can work soils of normal conformation. Check the degree of wear and condition of the hoe blades each day. If the blades should accidentally bend (or break) during work, they must be immediately replaced.

Remember to mount the new hoe blade in exactly the same position as the old one. If several hoe blades must be replaced, it is advisable to remove and assemble one hoe blade at a time in order to prevent positioning errors.

The steerage the soil is dry to clog it is, however, possible to mount 6 hoe blades per flange.

The heads of the bolts fixing the hoe blades in place must be on the side of the hoe blades themselves ,while the nut with relative washer must be on the flange side. Apply the tightening torques as listed in the chart.

If the hoe blades must be changed, remember to set the new blades in the same positions as the demounted ones.

REGULATION OF MECHANICAL SIDEWAY SHIFT MOVEMENT

The cultivator unit can be shifted sideways in relation to the three-point hitch. This makes the implement extremely versatile during the various work conditions.

Use of the hexagonal drive shaft allows the cultivator unit to quickly slide ,thus notably simplifying the operation.

The following operations must be carried out:

- 1 - Thoroughly clean the frame and relative guides to make the parts smoothly able to work.
- 2 - Slacken the screws that fix the brackets and leave these free.
- 3 - Use the requisite handwheel to move the carriage to the position required and then tighten two carriage fixing screws.

At the front, the carriage has two guide pads that should be replaced when worn.

IN WORK

Start work with the at running rate, gradually lowering the steerage hoe into the soil. Never excessively press down on the accelerator pedal when the pto is engaged. This could be very harmful for both the steerage hoe and the tractor itself.

When choosing how much to break up the soil which is to be rotary hoed the following points must be considered:

- The type of soil (mixed, sandy, clay etc.)
- How deep to hoe

- The forward moving speed of the tractor
- The optimal position of the rotary tiller
- The earth is best broken up and rotary hoed with a slow forward moving speed of the tractor, with The leveling blade lowered and a blade-carrying rotor rotation speed of about 200 rpm .As well as holding the earth that has already been hoed by the hoe blades the leveling blade helps to produce a well leveled and smooth surface after hoeing.
- If the leveling blade is raised the sods are no longer broken up and there will not be a smooth ,level finish.

CAUTION

- **In order to prevent breakages or damage ,the speed of the tractor must never exceed 10 km/hour when the implement is working.**
- **Stones or other sharp objects may be raised by the rotating hoe blades during the soil working phase. Constantly check that there are no persons, children or domestic animals within the field of action of the implement.**
- **Tractor operator must also take note of the above .**

TROUBLESHOOTING HINTS FOR THE TRACTOR OPERATOR/DRIVER

- a) Check the positioning of the two depth skids.
- b) Move forward more slowly as the power of the tractor may be insufficient.
- c) If the earth is too hard a second or third hoeing may be necessary.
- d) If the hoe blades are rotating on top of the earth instead of cutting into it proceed more slowly.

The earth is too finely broken up

- a) Raise the leveling blade.
- b) Increase the forward moving speed of the tractor.

The earth is not broken up finely enough

- a) Lower the leveling blade.
- b) Reduce the tractor speed.
- c) Don't work earth that is too wet.

Clogging up of the rotor

- a) The earth is too wet for hoeing.
- b) Raise the leveling blade.
Reduce the tractor speed.
- c) Avoid hoeing where there is long grass and carefully clean whatever debris has gathered on the supports on the sides of the rotor to avoid overheating.

The rotary hoe bounces over the earth or vibrates

- a) There are foreign bodies caught between the blades.
- b) The hoe blades have been incorrectly assembled thereby not forming the helix shape or with the blunt edge placed to cut into the earth first instead of the cutting edge.
- c) Worn or broken hoe blades.
- d) The rotor is deformed because of blows to the central part caused by foreign bodies present during hoeing.

Other problems

The rotary hoe does not hoe to the same depth over the whole e.g. if it hoes too deeply on the right side shorten the right arm of the lift bars and regulate the position of the lift bars and regulate the position of the right-hand skid.

Working a hill/slope

Where possible always try to <<work up>> the slope. If this is not possible avoid hoeing along the contours of the hill and down the slope to avoid a terracing effect.

Practical notes

The hoed earth should be in the right of the driver, The best system is to hoe alternate strips.

WARNING

- Always keep oils and greases well away from children's reach.
- Always thoroughly read the warnings and precautions indicated on the containers. Avoid contact with the skin.
- Always thoroughly and fully wash after use. The utilized oils should be treated in compliance with the current anti-pollution laws.

EVERY 8 WORK HOURS

- Grease the cardan shaft cross journals.
- Check that the bolts fixing the hoe blades are well tightened.
- Grease the rotor spindles.

EVERY 50 WORK HOURS

- Check the level of the oil in the gearbox or in the reduction unit and top up to the level mark on the rod as necessary.
- Transmission lateral par chaine: check the level of the oil in the side casing of the transmission unit, unscrewing the level plug and checking that oil flows out.
- Add oil through the fill plug if necessary. It should flow from the level plug.

Every 400 work hours

- Change the oil in the gearbox or in the reduction unit and transmission casing by completely draining off the old oil through the drain plug under the reduction unit and through the transmission drain plug.
- When this operation is carried out, it is also advisable to demount and clean the clutch disks (if the cardan shaft has a clutch).
- Check the tightening of the clutch springs.

6 , MAINTENANCE

It is advised that all the maintenance operations must be performed by qualified and trained people, with the machine still and disengaged from the tractor.

It is necessary to verify daily the wear state of the blades, replacing immediately the ones that are worn or damaged because their breaking may cause dangerous projections of components.

6.1 ROTOR

The rotor shaft has been preliminarily balanced: in case of replacement of a tool, it is advisable to replace all the series. To assemble not original tools can cause vibrations of the machines or breaking of the rolling bearings.

The replacement of the damaged parts must be performed exclusively by specialized people.

For the knives replacement interventions it is necessary to apply to specialized people making use of the assistance service by **Longreach Equipment** or its dealers.

6.2 ORDINARY MAINTENANCE

- Perform the maintenance with the machine disconnected by the tractor and opportunely positioned.
- Any maintenance work, regulation and cleaning must be performed with the machine to the ground, the engine of the tractor turn off, power taking disengaged, handbrake set on, ignition key disengaged and removed from the start panel
- Each 4 hours of work check the tension of the belts, You must always must care about their regulation



Perform this regulation only with the tractor turn off and power taking disengaged, remove the ignition key, wait until all the mechanisms are stopped.



In case of breakdown the operator must stop immediately the power taking, remove the ignition key, go out of the tractor to make sure of the entity of the problem and proceed with possible interventions on the machine.

6.3 GREASING AND LUBRIFICATION

Each 4 hours of work:

Verify camping of the nuts

Grease with lithium oil when it is indicated by the symbol **GREASE**

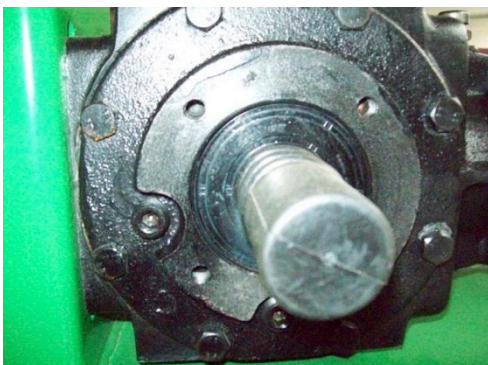







After 50 hr of work:

-verify the right amount of oil in the transmission unit and restore it till a good level, using oil type SAE 90 EP API GL4

Each 100hr of work:

-verify the right amount of oil in the transmission unit and restore it till a good level

Main Specifications of Rotary Tiller

Mod.		 HP					A	B	C	 KGS	
	CM	Min.	Max.	MM	n°	n°	RPM	CM	CM	100	KGS
IGNH90	90	16	20	140	4	9+9	540	113	95	100	317
IGNH105	105	20	28	140	5	12+12	540	123	95	100	327
IGNH125	125	25	30	140	6	15+15	540	143	95	100	340
IGNH135	135	25	35	140	7	18+18	540	153	95	100	348
IGNH150	150	30	50	140	8	21+21	540	173	95	100	359
IGNH180	180	40	70	140	9	24+24	540	203	95	100	380

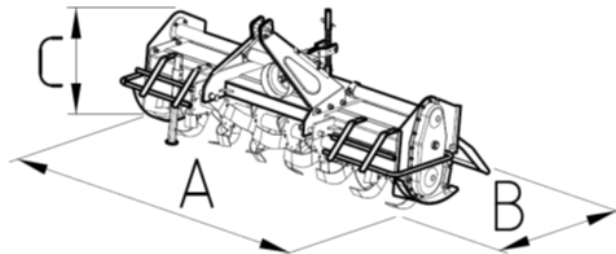

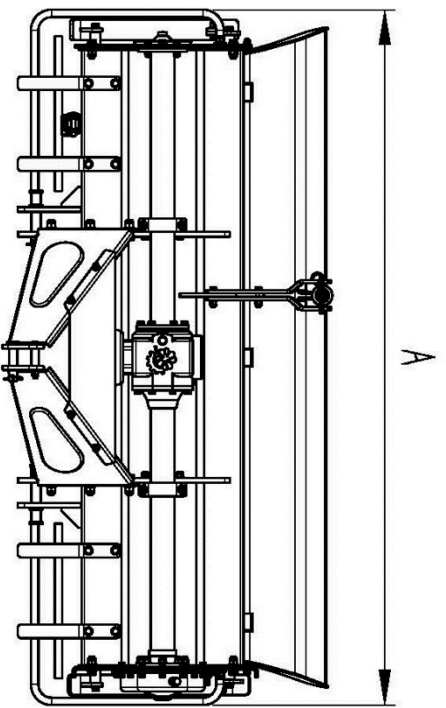
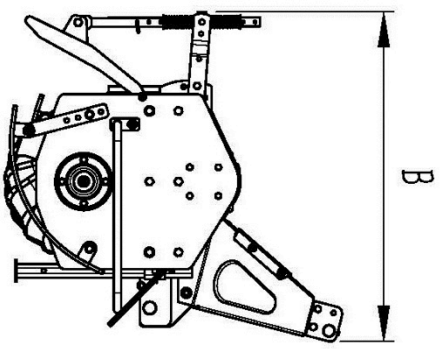
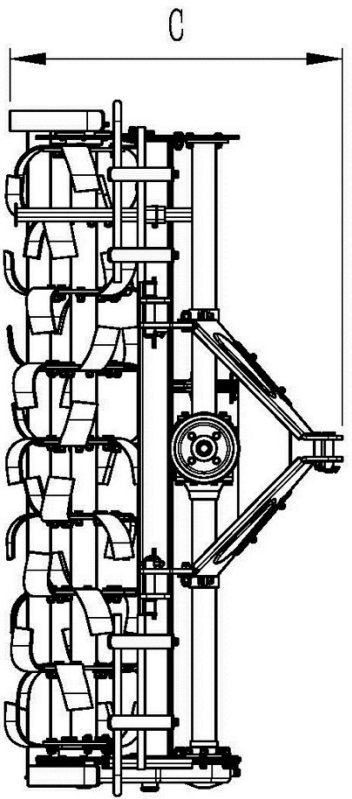

Mod	A	B	C
LB5	CM	CM	CM
LB5(OFL-95)	94	75	73
LT105	104	75	73
LT115(OFL-115)	114	75	73
LT125	124	75	73
LT135(OFL-135)	134	75	73
LT155(OFL-155)	144	75	73
GN80	113	95	100
GN105	123	95	100
GN125	143	95	100
GN135(OFL-135)	153	95	100
GN150(OFL-150)	173	95	100
GN180(OFL-180)	203	95	100
GN190(OFL-190)	153	95	100
GNH150	173	95	100
GNH180	203	95	100
GNH190	203	95	100
GNHADR-180	203	95	100

Mod	A	B	C
GNMA180	197	103	114
GNMA200	217	103	114
GNMA220	237	103	114
GNMA230	247	103	114
SB105	115	125	114
SB125	135	125	114
SB145	155	125	114
SB165	175	125	114
SB180	195	145	120
SG2180	197	103	114
SG2200	217	103	114
SG2220	237	103	114
SG2230	247	103	114

PRODUCT WARRANTY

1.0 DURATION OF THE WARRANTY PERIOD

LONGREACH EQUIPMENT warrants all its three point linkage products as free of defects in material and in workmanship for two years from the date of purchase of the machine. All other products are warranted for a period of 12 months from date of purchase.

2.0 WARRANTY CONDITIONS

2.1 The commitment of this warranty is limited only to the replacement and/or repair of those elements considered to be defective in material or workmanship after an inspection by our technician (or authorised dealer)

2.2 The damaged elements must be in unaltered condition, not disassembled by unauthorised persons and furthermore must not have been subject to misuse, negligent use or care, neglect, careless operation or handling, or accident

2.3 It is the responsibility of the dealer or customer to return the item to the place of purchase to enable authorised warranty repairs to be conducted

2.4 No warranty repair performed by someone other than *LONGREACH EQUIPMENT* or its appointed agent shall be considered valid or binding

2.5 The manufacturer holds the right to perform modifications without prior notice and whenever modifications take place the manufacturer shall not be obliged to carry out these modifications on products manufactured previously

2.6 Any warranty claim by the purchaser must be lodged with the dealer from which the machine was purchased. The dealer will prepare a detailed report in writing of the claim, including anticipated workshop hours, prior to any work being authorised by *LONGREACH EQUIPMENT*, and any subsequent repair work commencing

2.7 The warranty does not cover:

2.7.1 Damage due to a manoeuvre error

2.7.2 Damage due to repairs made by unauthorised people or use of non-original spare parts

2.7.3 When instructions written in the operator manual are not followed

2.7.4 Consumable items (eg belts, hammers, flails)

2.7.5 Damage due to normal wear and tear, or blockages (eg fencing wire)