

# VMA 240



**LONGREACH**  
EQUIPMENT



- Extra heavy duty construction
- Rear door to enable ejection of grass in heavy mowing applications
- Easy maintenance and replacement of hammers
- Ideal machine in vineyards and orchards
- 5 belt "b" section belt drive
- Precisely manufactured and balanced rotor
- High strength long life hammers
- Hydraulic offset fitted standard
- Manufactured to the highest European standard
- 2 year full factory warranty. Full spare parts availability.

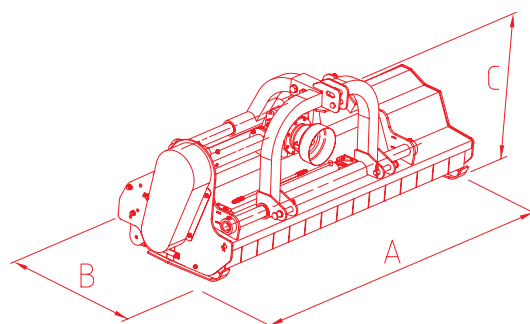

	hp							A	B	C	KG
cm	min	max	cm	n°	n°	n°	rpm	cm	cm	cm	kgs
239	60	120	52 + 127 92 + 87	24	N/A	5	540	255	128	100	675

PRICE